

INSTRUCTIONS FOR COMPRESSION ESTER

Test Procedure

1. Run the engine for about ten minutes or until it reaches normal operating temperature before performing the compression test.
2. Stop the engine. Disconnect all the spark plug wires and number them in the order in which they were removed; this makes them easy to identify for reconnection.
3. Loosen all spark plugs about one turn, but do not remove them. Use an air hose or stiff brush to remove all the dirt from the spark plug wells. Remove the spark plugs and place them on a clean flat surface in the order in which they were removed. This procedure will help to correlate any compression or cylinder problems with the condition of the plug from the particular cylinder involved.
4. Remove the air filter and set the carburetor throttle plates to the wide open throttle position using a string or wire. See Figure 1.

CAUTION!

Failure to return the carburetor throttle plates to the closed throttle position before starting the engine can cause serious engine damage.

Fig. 1 Hold Open Throttle Plates

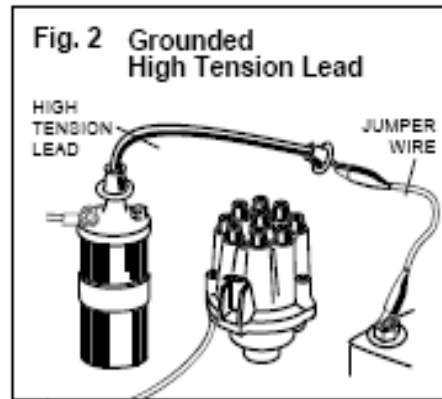
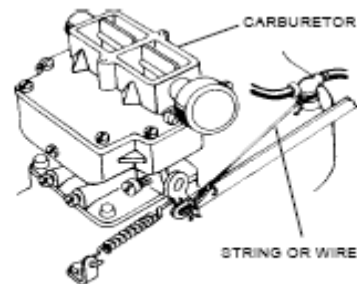

5. Remove the high tension lead from the center of the distributor and connect to ground as shown in Figure 2. To disable electronic ignition systems, disconnect the electronic ignition module or remove the primary battery terminal from the ignition coil. On GM HEI V-8 and V-6, disconnect the primary lead from the distributor cap. (Figure 3.)

Fig. 3 Disabled GM HEI Ignition System

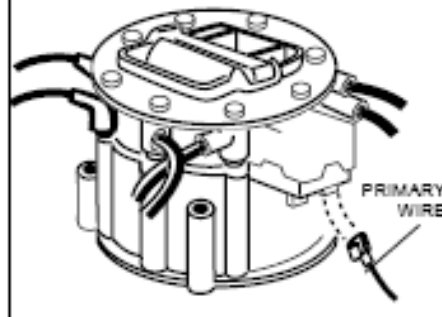

6. Disconnect the hose from the gauge. Screw the spark plug adapter hose (Item 3, Figure 6) into a spark plug well. Hand tighten only – DO NOT USE A WRENCH See Figure 6.
- NOTE:** On engines with 14mm long reach plugs, use the long reach adapter (Item 7, Figure 6).

Do not use the adapter in short reach holes – it may hit the top of the piston and damage the engine.

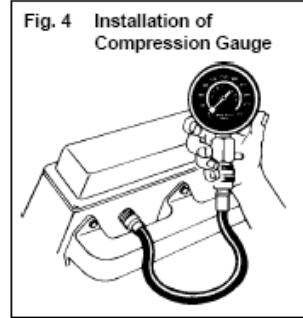

7. Insert the spark plug hose into the gauge by pulling up on the outer sleeve of the gauge's quick disconnect coupling and allow it to snap back as the fitting engages the adapter.
8. Crank the engine for at least four compression strokes or until the pressure reading stops rising on the gauge.
9. Record the compression reading then push the side release valve to relieve the pressure as shown in Figure 5. Repeat the test. Record the reading, relieve the pressure, remove the gauge from the hose, and remove the hose from the spark plug well.

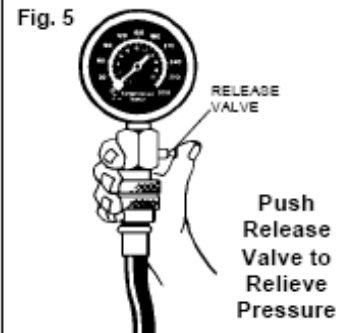

10. Reconnect the hose to the next spark plug well to be tested and repeat steps 6 through 10 for the remainder of the cylinders to be tested.

Test Results

1. On a normal cylinder, the gauge needle should travel up-scale on each compression stroke until it reaches a peak value. All cylinders should indicate a pressure that is within the vehicle manufacturer's specifications, and the

- reading should not vary more than 10% from cylinder to cylinder
2. If the needle fails to travel up-scale as described in Step 1, or if it remains at the same value for several strokes and then starts to climb, the cylinder has a sticking valve.
 3. If the compression reading is considerably higher than the vehicle manufacturer's specification, it indicates Carbon buildup in the cylinder.
 4. If a reading on two adjacent cylinders is 20 pounds (or more) lower than the other cylinders, a defective head gasket is indicated. Water (coolant) and/or oil may be found in the two cylinders under these conditions.
 5. If the readings are low or vary widely between cylinders, pour a teaspoon of clear S.A.E. grade 30 oil into each cylinder and retest. If the readings increase considerably the fault may be due to poorly seated or worn piston rings. If the readings remain about the same the valves and/or associated components are likely the cause.
 6. Clean, regap and reinstall the spark plugs in the same order in which they were removed, or install new spark plugs. Reconnect all spark plug wires in the proper order.
- Remove the string or wire from the carburetor throttle plates and make certain it returns to closed Throttle position.**
- Reconnect the ignition system.

Fig. 6

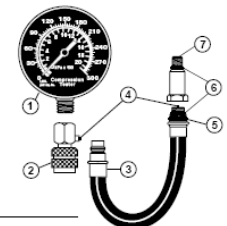

Compression Gauge Repair Parts

Key No.	Part No.	Description
1	0031-000-0246	Compression Gauge
2	0180-000-0772	Quick Disconnect Coupling & Valve Assembly
3	0032-000-0109	Spark Plug Hose Assembly
4	0180-000-0775	(2 ea) Air Valve (High Pressure)*
5	0400-000-1350	O-ring
6	0400-000-1349	(2 ea) O-ring
7	0180-000-0895	Deep Reach Adapter
	0002-004-2018	Instruction Manual (Not illustrated)

*NOTE: Do not use automotive tire air valve as a replacement part.